

Spring Kit Contents

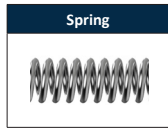

Seal Kit Contents



Manual Override Kit Contents

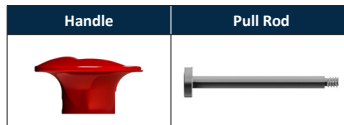

WARNING
If the valve is disconnected from a system, it must be depressurized, cycled, and purged.

CAUTION
Care should be taken to not scratch or damage sealing surfaces.

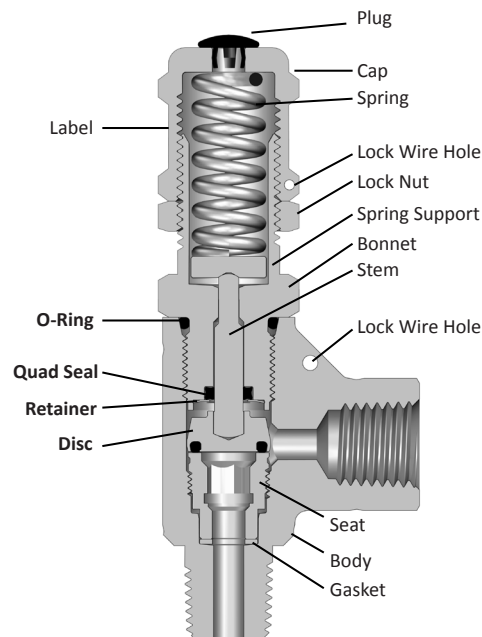

RL3

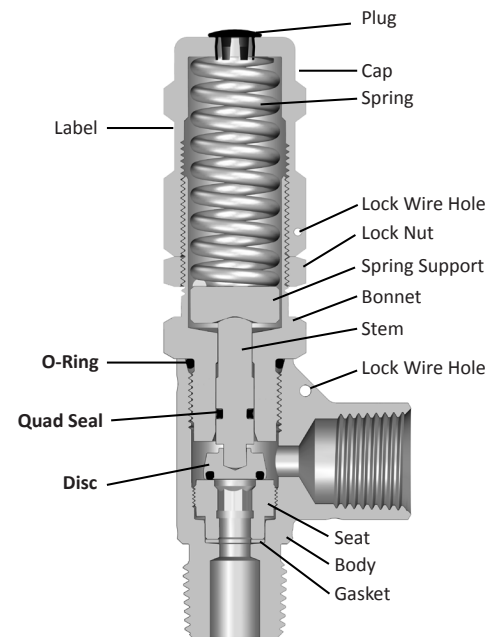

RL4

Spring Kit Instructions

1. Remove valve from system.
2. Loosen **lock nut** and remove **cap** from **bonnet**.
3. Remove the **spring** and discard.
4. Insert the new **spring**.
5. Thread the **cap** onto the **bonnet** 9 turns.
6. Proceed to **Adjusting the Set Pressure**.

Seal Kit Instructions

1. Remove valve from system.
2. Loosen **bonnet**.
3. Remove **bonnet** from **body**.
4. Remove **disc** from **body** and discard.

5. Remove stem and **O-Ring** from **bonnet**. Discard **O-Ring**.
6. **RL3 Only:** Remove retainer and discard.
7. Remove **quad seal** and discard.
8. Make sure all parts are clean before reassembly.
9. Install new **quad seal** (lubricate with system compatible lubricant).
10. **RL3 Only:** Install new **retainer** (teeth of retainer must face away from quad seal).
11. Install new **O-Ring** onto **bonnet** (lubricate with system compatible lubricant).
12. Lubricate tip of **stem** and insert into **bonnet**.
13. Install new **disc** on **stem**.
14. With components upside-down, thread **bonnet** into **body**.
15. Tighten bonnet to • **RL3: 400 in.·lb (45.2 N·m)**
• **RL4: 600 in.·lb (67.8 N·m)**
16. Proceed to **Adjusting the Set Pressure**.

Manual Override Conversion

1. Remove valve from system.
2. Loosen **lock nut** and remove **cap** from **bonnet**.
3. Remove **plug** from **cap** and discard.
4. Remove **spring** from **bonnet**.
5. Remove **spring support** and discard.
6. Install **pull rod** into **bonnet**.
7. Place **spring** over **pull rod**.
8. Place **cap** over **pull rod**, resting it on **bonnet**.
9. Screw **handle** onto **pull rod**. Tighten set screw on **handle** to **10 in.·lb (1.1 N·m)** with 5/64 in. hex bit.
10. Thread the **cap** onto the **bonnet** 9 turns.
11. Proceed to **Adjusting the Set Pressure**.

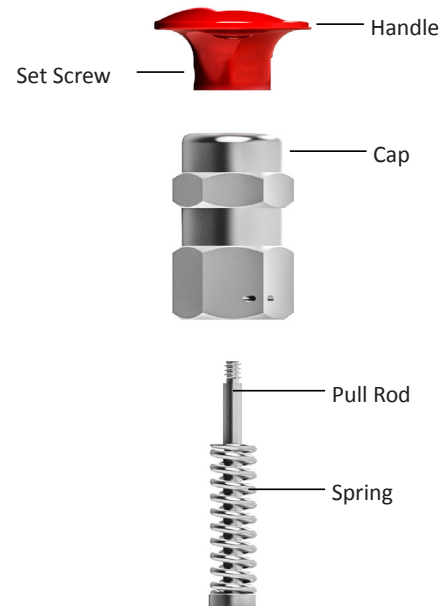

Adjusting the Set Pressure

NOTE: Adjust the set pressure before installing the valve in a system

1. Tighten **lock nut** against the **cap**.
2. Test set pressure.
3. Adjustment of set pressure:
 - Relieve system pressure and loosen **lock nut**.
 - Turn **cap** clockwise to increase set pressure.
 - Turn **cap** counterclockwise to decrease set pressure.
4. Repeat steps 1 through 3 until desired pressure is obtained.
5. With backup wrench on **cap**, tighten **lock nut** to **100 in.·lb (11.3 N·m)**.
6. Install valve in system.