



Multipurpose Ball Valves



FB Series



Live Loaded Seats

- Leak-tight seal in high and low system pressures
- Compensate for seat wear



Robust Body and Stem Seals

- Leak tight envelope
- No need for packing adjustment



Floating Ball

- Upstream pressure assists sealing against the downstream seat



Three-Piece Design

- Wide variety of end connections
- Easier maintenance





At SSP we are proud to be an **American success story** and each day our products are specified and used across America and the rest of the world.

100% of our products are made in the USA and are manufactured in our 165,000 sq. ft. facility based near Cleveland, Ohio. Throughout our manufacturing we use the latest technology and quality control procedures.

Our facility is the largest single-site operation in the entire industry and includes tool and die design, production, custom closed-die forging, machining, finishing operations, assembly and rigorous product testing.

We also carefully select each of our supply chain partners, many of whom are local using the latest in Kaizen and Six Sigma methodology.

TABLE of CONTENTS

Introduction	3	Ordering Information	7
Features	4	Options	8
Temperature and Pressure Ratings	5	Special Order Instructions	10
Materials of Construction	5	Testing, Safety, Warranty	10

FB Series Multipurpose Ball Valves

FB Series ball valves use a unique combination of features to provide leak-tight performance at high and low pressures and temperatures, high cycle-life, low maintenance, lower actuating torque, and design flexibility.

Features include:

- Pressure range: up to 6000 PSIG (413 bar)
- Temperature range: -15 to 400°F (-26 to 204°C)
- Flow: Cv up to 13.8
- Live-loaded seats
- Robust body and stem seals
- Wide variety of end connection size and type combinations
- Choice of Duolok, Griplok and Unilok tube fitting end connections

LFB Series Low-Temperature Ball Valves

LFB low-temperature ball valves are designed with materials selected for applications requiring temperature ratings from -40 to 200°F (-40 to 93°C).

Applications

FB Series ball valves are very versatile. They can be used in both high and low pressure instrumentation systems, process lines, utility systems, and other applications. Designed for higher pressures than many floating ball valves, they can be used in applications such as high-pressure CNG filling station supply lines, equipment and in instrumentation and control systems. Unlike many floating ball designs, FB Series valves are also suitable for low and dynamic pressure conditions. In addition, end-screw construction allows users to specify a wide variety of end connection size and type combinations.

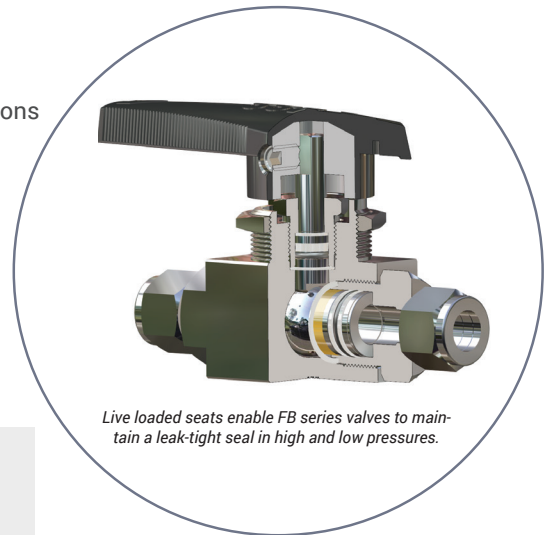

Live loaded seats enable FB series valves to maintain a leak-tight seal in high and low pressures.

Product Design

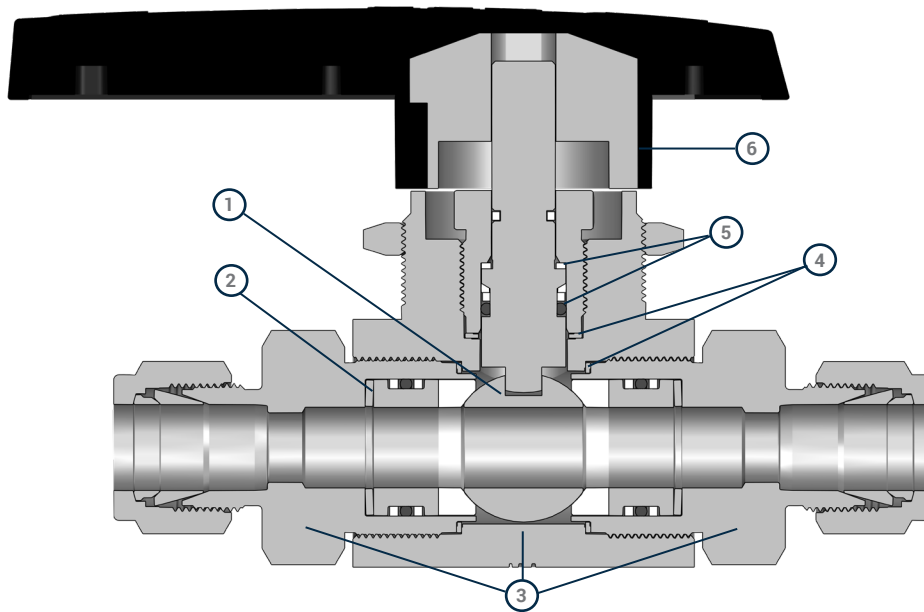

Drop in replacement size for Swagelok® AFS and SK Series Valves.
Meets ASME B31.3 design pressure calculations.

- | | |
|--|--|
| <p>1 FLOATING BALL DESIGN</p> <ul style="list-style-type: none"> • Upstream pressure assists sealing against the downstream seat | <p>4 ROBUST BODY SEALS</p> <ul style="list-style-type: none"> • Leak-tight envelope |
| <p>2 LIVE-LOADED SEATS</p> <ul style="list-style-type: none"> • Improves sealing in high, low and dynamic pressure and flow conditions • Fully supported seats improve cycle-life | <p>5 STEM BEARING AND O-RING STEM SEAL</p> <ul style="list-style-type: none"> • Leak-tight seal • Lower actuation torque • No need for packing adjustments |
| <p>3 THREE-PIECE DESIGN</p> <ul style="list-style-type: none"> • Wide variety of end connection type and size combinations • Three tube fitting designs • Easier maintenance | <p>6 DURABLE DIRECTIONAL HANDLE</p> <ul style="list-style-type: none"> • Stainless steel reinforced nylon handle for durability • Indicates flow direction • Large ergonomic handle for easier actuation |

Temperature Pressure Tables

Seat Material	PTFE	PEEK					
End Connections	All	D4 to D8 DM6 to DM12	D12 DM16	D16	4PF to 12PF 4FRT & 8FRT	4PM to 8PM	S6 & S8 SS6 & SS8
Temperature, F (C)	Working Pressure, psig (bar)						
<i>FB Series</i>							
-15 (-26) to 100 (37)	1500 (103)	6000 (413)	5800 (400)	5500 (379)	6000 (413)	6000 (413)	6000 (413)
150 (65)	1250 (86.1)						
200 (93)	1000 (68.9)						
250 (121)	600 (41.3)						
300 (148)	300 (20.6)	3000 (206)	3000 (206)	3000 (206)	3000 (206)	3000 (206)	3000 (206)
350 (176)	100 (6.89)	2000 (138)	2000 (138)	2000 (138)	2000 (138)	2000 (138)	2000 (138)
400 (204)	-	1000 (68.9)	1000 (68.9)	1000 (68.9)	1000 (68.9)	1000 (68.9)	1000 (68.9)
<i>LFB Series</i>							
-40 (-40) to 100 (37)	1500 (103)	6000 (413)	5800 (400)	5500 (379)	6000 (413)	6000 (413)	6000 (413)
150 (65)	1250 (86.1)						
200 (93)	1000 (68.9)						

Materials of Construction

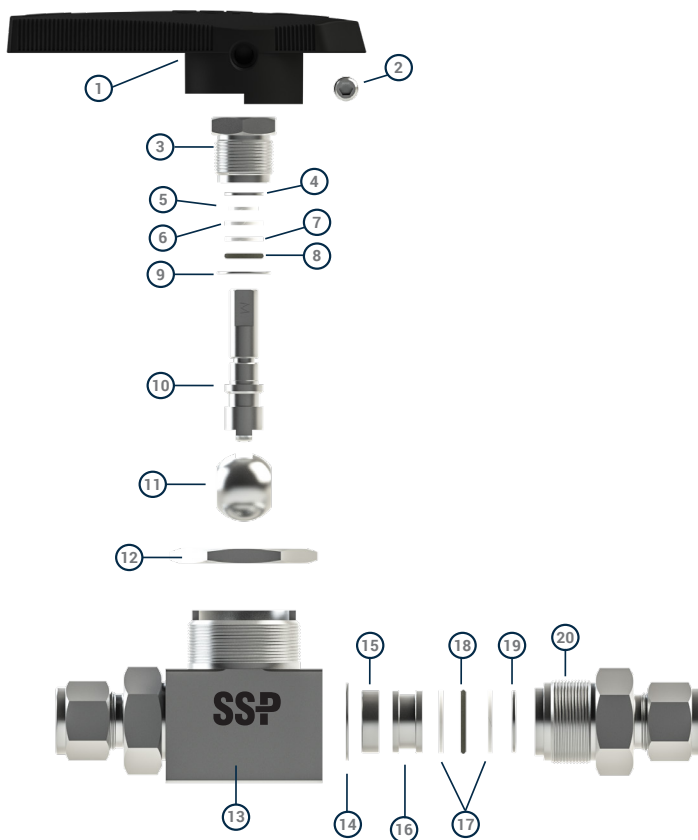

ID	Component	Material / Specification
1	Handle	Nylon with SS Insert
2	Handle Set Screw	17-4PH
3*	Packing Bolt	316 SS/A479
4	Stem Bearing	PEEK
5	Stem Guide Ring	PTFE / D1710
6	Chamfered Back-up Ring	PEEK
7	Stem Back-up Ring	PTFE / D1710
8*	Stem O-ring	Fluorocarbon FKM (FB) Low-Temp Nitrile (LFB)
9*	Packing Bolt Gasket	Silver-Plated 316 SS/A240
10*	Stem	316 SS/A276
11*	Ball	316 SS/A276
12	Panel Nut	Powder Metal 316 SS/B783
13*	Body	316 SS/A182
14*	End Screw Gasket	Silver-Plated 316 SS/A240
15*	Seat	PEEK or PTFE /D1710
16*	Seat Gland	316 SS/A479
17*	Seat Back-up Rings	PTFE / D1710
18*	Seat O-ring	Fluorocarbon FKM (FB) Low-Temp Nitrile (LFB)
19*	Seat Spring	316 SS/A240 OR A666
20*	End Screw	316 SS/A479
	Lubricant	PTFE-Based

*Wetted components

How it works

The images below explain how live-loaded seats work to keep a leak-tight seal in high and low pressures, reduce actuation torque and improve cycle life.

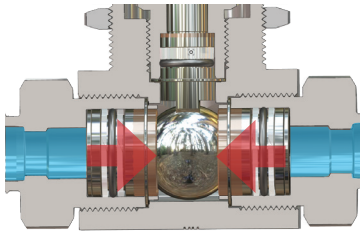

Open

When the valve is open fluid flows through the valve (blue). Force from the springs (red arrows) apply pressure evenly to the seat gland, seat and ball.

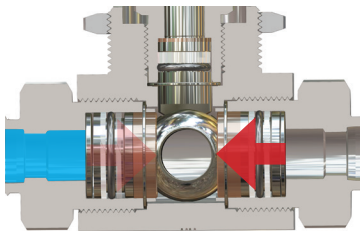

Closed - High Pressure

When the ball is closed under high pressure, the force of the upstream pressure forces the ball against the downstream seat to form a tight seal. Resistance from the downstream spring cushions the force of the ball against the seat to protect the seat and makes the valve easier to actuate.

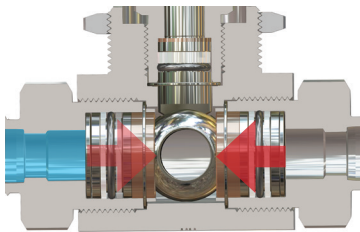

Closed - Low Pressure

Under low pressure, there is much less upstream pressure on the ball and downstream seat. Without the mechanical force exerted by the seats and springs, the ball could disengage from the downstream seat.

Ordering Instructions

Ordering FB Series valves requires the following steps:

- ① Locate the basic part number with the required orifice size and end connection type and size.
Example: 38PD8-316 Note: Duolok Tube Fitting end connections are standard. Unilok, and Griplok tube fitting end connections are also available. To order, please see Tube Fitting End Connections on page 8.
- ② Add designators for other options. (See pages 8-9) *Example: 38PD8-316-RD-XP98*

NOTE: The Part Number and Dimensions Tables contain the most popular part numbers. Valves can be configured with different end connection types and sizes. Please use the special order table on page 10 to construct a part number for quote. *Example: 38PD86PF-316-RD-XP98*

Ordering Information

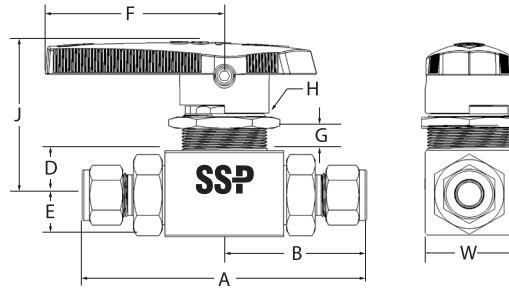

Part Numbers and Dimensions

Connection		Part Number	Orifice	Cv	Dimensions, in. (mm)								
Type(s)	Size				A	B	D	E	F	G	H	J	W
Fractional Tube Fitting	1/4 in.	36PD4-316	0.188	1.3	3.60 (91.4)	1.80 (45.7)	0.44 (10.8)	0.44 (10.8)	1.43 (36.3)	3/16	25/32	1.53 (38.9)	1.00 (25.4)
	3/8 in.	36PD6-316	0.250	2.5	3.73 (91.5)	1.86 (47.2)	0.44 (10.8)	0.44 (10.8)	1.43 (36.3)	3/16	25/32	1.53 (38.9)	1.00 (25.4)
	1/2 in.	38PD8-316	0.406	7.2	4.80 (122)	2.40 (61.0)	0.75 (19.1)	0.70 (17.8)	3.02 (81.3)	3/8	1 1/2	2.59 (65.8)	1.50 (36.8)
	3/4 in.	38PD12-316	0.472	7.1	4.80 (122)	2.40 (61.0)	0.75 (19.1)	0.70 (17.8)	3.02 (81.3)	3/8	1 1/2	2.59 (65.8)	1.50 (36.8)
	1 in.	38PD16-316 ¹	0.472	6.5	5.10 (130)	2.55 (64.8)	0.75 (19.1)	0.70 (17.8)	3.02 (81.3)	3/8	1 1/2	2.59 (65.8)	1.50 (36.8)
Metric Tube Fitting	6 mm	36PDM6-316	0.188	1.3	3.60 (91.4)	1.80 (45.7)	0.44 (10.8)	0.44 (10.8)	1.43 (36.3)	3/16	25/32	1.53 (38.9)	1.00 (25.4)
	8 mm	36PDM8-316	0.250	2.5	3.68 (93.5)	1.84 (46.7)	0.44 (10.8)	0.44 (10.8)	1.43 (36.3)	3/16	25/32	1.53 (38.9)	1.00 (25.4)
	10 mm	36PDM10-316	0.250	2.5	3.75 (95.3)	1.88 (47.8)	0.44 (10.8)	0.44 (10.8)	1.43 (36.3)	3/16	25/32	1.53 (38.9)	1.00 (25.4)
	12 mm	38PDM12-316	0.375	5.2	4.80 (122)	2.40 (61.0)	0.75 (19.1)	0.70 (17.8)	3.02 (81.3)	3/8	1 1/2	2.59 (65.8)	1.50 (36.8)
	16 mm	38PDM16-316	0.472	12.4	4.80 (122)	2.40 (61.0)	0.75 (19.1)	0.70 (17.8)	3.02 (81.3)	3/8	1 1/2	2.59 (65.8)	1.50 (36.8)
Female NPT	1/4 in.	36P4PF-316	0.250	2.5	2.91 (73.9)	1.46 (37.1)	0.44 (10.8)	0.44 (10.8)	1.43 (36.3)	3/16	25/32	1.53 (38.9)	1.00 (25.4)
	3/8 in.	38P6PF-316	0.472	11.0	4.00 (102)	2.00 (50.8)	0.75 (19.1)	0.70 (17.8)	3.02 (81.3)	3/8	1 1/2	2.59 (65.8)	1.50 (36.8)
	1/2 in.	38P8PF-316	0.472	13.8	4.00 (102)	2.00 (50.8)	0.75 (19.1)	0.70 (17.8)	3.02 (81.3)	3/8	1 1/2	2.59 (65.8)	1.50 (36.8)
	3/4 in.	38P12PF-316 ¹	0.472	7.8	4.12 (105)	2.06 (52.3)	0.75 (19.1)	0.70 (17.8)	3.02 (81.3)	3/8	1 1/2	2.59 (65.8)	1.50 (36.8)
Male NPT	1/4 in.	36P4PM-316	0.250	2.5	3.23 (82.0)	1.62 (41.0)	0.44 (10.8)	0.44 (10.8)	1.43 (36.3)	3/16	25/32	1.53 (38.9)	1.00 (25.4)
	3/8 in.	38P6PM-316	0.375	5.2	4.22 (107)	2.11 (58.6)	0.75 (19.1)	0.70 (17.8)	3.02 (81.3)	3/8	1 1/2	2.59 (65.8)	1.50 (36.8)
	1/2 in.	38P8PM-316	0.472	13.8	4.59 (117)	2.29 (58.3)	0.75 (19.1)	0.70 (17.8)	3.02 (81.3)	3/8	1 1/2	2.59 (65.8)	1.50 (36.8)
Female ISO	1/4 in.	36P4FRT-316	0.250	2.5	2.91 (73.9)	1.46 (37.1)	0.44 (10.8)	0.44 (10.8)	1.43 (36.3)	3/16	25/32	1.53 (38.9)	1.00 (25.4)
	1/2 in.	38P8FRT-316	0.472	13.8	4.00 (102)	2.00 (50.8)	0.75 (19.1)	0.70 (17.8)	3.02 (81.3)	3/8	1 1/2	2.59 (65.8)	1.50 (36.8)
Male ORFS	3/8 in.	36PS6-316 ¹	0.250	2.5	3.10 (78.8)	1.55 (39.4)	0.44 (10.8)	0.44 (10.8)	1.43 (36.3)	3/16	25/32	1.53 (38.9)	1.00 (25.4)
	1/2 in.	38PS8-316	0.378	5.2	4.06 (103)	2.03 (51.6)	0.75 (19.1)	0.70 (17.8)	3.02 (81.3)	3/8	1 1/2	2.59 (65.8)	1.50 (36.8)
Female ORFS	3/8 in.	36PSS6-316 ¹	0.250	2.5	3.73 (94.7)	1.87 (47.4)	0.44 (10.8)	0.44 (10.8)	1.43 (36.3)	3/16	25/32	1.53 (38.9)	1.00 (25.4)
	1/2 in.	38PSS8-316	0.358	4.8	4.83 (123)	2.41 (61.3)	0.75 (19.1)	0.70 (17.8)	1.43 (36.3)	3/8	1 1/2	2.59 (65.8)	1.50 (36.8)

¹Not recommended for panel mounting.

Tube Fitting End Connections

SSP offers three tube fitting designs. Duolok two-ferrule tube fittings are standard. To select a different design, select the designator from the table below, then substitute it for the "D" in the part number. *Example: 38PU8-316 for Unilok tube fitting end connections.* For more information about SSP tube fittings see our tube fitting catalogs or go to www.mySSP.com

Design	Description	Designator
Duolok	2-Ferrule	D
Unilok	1-Ferrule	U
Griplok	2-Ferrule	G

Handle Options

Stainless steel reinforced black nylon handles are standard on FB Series ball valves. To select a different handle, add the designator from the table below to the basic part number. *Example: 38PD8-316-GR*

Handle color	Designator
Black	None
Green	-GR
Red	-RD
Blue	-BL
Yellow	-YW
Orange	-OG
No Handle	-NH

Replacement Handles

Replacement handles are shipped with the set screw installed. To order replacement handles, select the base part number from table below, then add the color designator from the Handle Options table to the end of the part number. For black replacement handles use a -BK color designator. *Example: NY-7K-38-OG*

Valve Series	Part Number
36 / L36	NY-7K-36-XX
38 / L38	NY-7K-38-XX

Seat Material

FB Series valves listed in the dimensions table, include a standard PEEK seat material. To order valves with PTFE seat material, replace the P in the basic part number with material designator T. *Example: 36TD4-316*

Seat Material	Designator
PEEK	P
PTFE	T

Locking Devices

Factory installed locking handle hardware can be added to any size valve by adding -LD to the part number. *Example: 38PD8-316-LD.* Locking handle kits for field installation can be ordered using the part numbers in the table below.

Valve Series	Part Pumber
36 / L36	36-LDK-316
38 / L38	38-LDK-316

Rebuild Kits

Rebuild kits can be ordered using a part number from the table below.

SEAT KITS: Seat rebuild kits contain seats, seat backup rings, seat o-rings, seat springs, end screw gaskets, lube, SDS and instructions.

STEM AND SEAT KITS: Stem and Seat rebuild kits contain stem o-ring, stem back-up ring, stem chamfered back-up ring, stem bearing, packing bolt gasket, seats, seat backup rings, seat o-rings, seat springs, end screw gaskets, lube, SDS and instructions.

Series	Seat Kits		Stem & Seat Kits	
	PEEK Seat	PTFE Seat	PEEK Seat	Seat
36	36P-RK1	36T-RK1	36P-RK2	36T-RK2
L36	L36P-RK1	L36T-RK1	L36P-RK2	L36T-RK2
38	38P-RK1	38T-RK1	38P-RK2	38T-RK2
L38	L38P-RK1	L38T-RK1	L38P-RK2	L38T-RK2

Special Cleaning

FB Series valves are available cleaned in compliance with ASTM G93 Level C and CGA G-4.1, *Cleaning Methods and Cleanliness Levels for Material and Equipment Used in Oxygen-Enriched Environments.* To specify special cleaning, add -XP98 to the part number. *Example: 38PD8-316-XP98*

For more information about other types of special cleaning, please contact your local SSP distributor or SSP Customer Service.

ECE R110-Type Approval

LFB Series valves are available with ECE R110-type approval. Valves with this approval have low-temp Nitrile stem and seat O-rings and PEEK seats.

- ECE R110 Manual Service Valve Type Approval
Classification: Class 6
Pressure: 3988 psig (275 bar)
Temperature: -40 to 185°F (-40 to 85°C)

To order, add **-R110** to the valve ordering number.

Example: L36PD4-316-**R110**

Actuator Brackets & Couplings

Actuator brackets and couplings are available for ISO 5211 compliant actuators. Actuator kits contain the actuator bracket, coupling and fasteners required to install the actuator bracket and connect to the actuator.

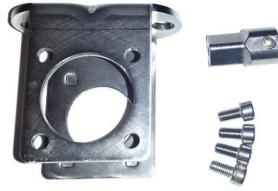

Valve Series	ISO 5211 Flange Size	Coupling Size	Fastener Type	Part Number
36 / L36	F04	11 mm ISO	Metric	36-MB-F04-11ISO-M
			Fractional	36-MB-F04-11ISO-F
		11 mm DIN	Metric	36-MB-F04-11DIN-M
			Fractional	36-MB-F04-11DIN-F
	F05	11 mm ISO	Metric	36-MB-F05-11ISO-M
			Fractional	36-MB-F05-11ISO-F
		11 mm DIN	Metric	36-MB-F05-11DIN-M
			Fractional	36-MB-F05-11DIN-F
		14 mm ISO	Metric	36-MB-F05-14ISO-M
			Fractional	36-MB-F05-14ISO-F
		14 mm DIN	Metric	36-MB-F05-14DIN-M
			Fractional	36-MB-F05-14DIN-F
38 / L38	F05	11 mm ISO	Metric	38-MB-F05-11ISO-M
			Fractional	38-MB-F05-11ISO-F
		11 mm DIN	Metric	38-MB-F05-11DIN-M
			Fractional	38-MB-F05-11DIN-F
		14 mm ISO	Metric	38-MB-F05-14ISO-M
			Fractional	38-MB-F05-14ISO-F
		14 mm DIN	Metric	38-MB-F05-14DIN-M
			Fractional	38-MB-F05-14DIN-F
		17 mm ISO	Metric	38-MB-F05-17ISO-M
			Fractional	38-MB-F05-17ISO-F
		17 mm DIN	Metric	38-MB-F05-17DIN-M
			Fractional	38-MB-F05-17DIN-F
	F07	17 mm ISO	Metric	38-MB-F07-17ISO-M
			Fractional	38-MB-F07-17ISO-F
		17 mm DIN	Metric	38-MB-F07-17DIN-M
			Fractional	38-MB-F07-17DIN-F

Actuation Torque

Use the table below to select the correct actuator for the valve and application. The values listed are minimum required actuator torque at maximum system pressure for each valve.

Valve Series							
36		L36		38		L38	
in-lb (N-m)							
Start	End	Start	End	Start	End	Start	End
30 (3.4)	6 (0.7)	51 (5.8)	19 (2.1)	96 (10.8)	23 (2.6)	176 (19.9)	53 (6.0)

Actuated Ball Valve Assemblies

FB Series valves are available with a wide range of actuators, solenoids, and limit switches selected specifically for each valve's requirements.



For more information, see the SSP Actuated Ball Valve Assemblies Catalog, contact SSP Customer Service, or visit www.mySSP.com.

Sour Gas Service

Selecting valves for sour gas applications requires the consideration of several factors including the temperature, pH, partial pressure of H₂S, and whether the application is above or below ground. SSP offers configurations to meet the requirements in ANSI/NACE MR0175/ISO 15156-3 and NACE MR0103/ISO 17945. To order valves for sour gas applications, add the designator below to the part number. *Example: 38PD8-316-SG1*

Designator	Wetted Part ¹	Non-Wetted	Body	O-ring
SG1	Annealed 316 SS except body ²	316 SS	316 SS	EP
SG2	Annealed 316 SS	316 SS	316 SS	EP
SG3	Alloy 400/UNS S20910	316 SS	Alloy 400	FFKM

¹Springs or other components may require other materials for functionality.

²Compression fittings and valve bodies with compression fitting ports are exempt from lower hardness requirements per ANSI/NACE MR0175/ISO 15156 and NACE MR0103/ISO 17945.

Special Orders

The Basic Ordering Numbers and Dimensions tables (page 7) contain only the most popular valve configurations; many more are available. If the required valve configuration is not in the Basic Ordering Numbers and Dimensions tables, use the chart below to build part numbers for quotation purposes.

(basic ordering number)

(options)

A **B** **C** **D** **E**
38P D8 6PF -316 -GR -LD -SG1

<p>A TEMPERATURE Blank Standard (FB) L Low-Temperature (LFB)</p>	<p>B VALVE SIZE/SEAT MATERIAL 36P 0.250 Ball Orifice - PEEK Seats 36T 0.250 Ball Orifice - PTFE Seats 38P 0.472 Ball Orifice - PEEK Seats 38T 0.472 Ball Orifice - PTFE Seats</p>
<p>C INLET TYPE² + OUTLET TYPE² D Duolok® Tube Fitting Fractional Sizes: Metric Sizes: U Unilok® Tube Fitting 4 1/4 in. M6 6 mm G Griplok® Tube Fitting 6 3/8 in. M8 8 mm DM Duolok® Metric 8 1/2 in. M10 10 mm PF Female NPT 12 3/4 in. M12 12 mm PM Male NPT 16 1 in. M16 16 mm FRT Female ISO Tapered S Male ORFS SS Female ORFS</p>	<p>D BODY MATERIAL -316 316 SS Additional Valve Materials Alloy 400/405 and Alloy C-276 materials are available for FB series valves. Contact SSP for more information</p>

E OPTIONS¹

<p>HANDLES (Blank) Black -GR Green -RD Red -BL Blue -YW Yellow -OG Orange -NH No Handle</p>	<p>SPECIAL CLEANING -XP98 Per ASTM G93 Level C and CGA G-4.1</p>	<p>OTHER OPTIONS -LD Locking Hardware -SG* Sour Gas *See Sour Gas Options on page 8. -R110 ECE R110 Approved valve (L36P/L38P series only)</p>
--	---	--

Important Information



IMPROPER SELECTION OR IMPROPER USE OF THE PRODUCTS DESCRIBED HEREIN OR RELATED ITEMS CAN CAUSE PERSONAL INJURY AND PROPERTY DAMAGE. It is the sole responsibility of the system designers and users to properly select and use products for their specific applications. This document has been provided to users with technical expertise as a reference for further investigation to determine specific product needs relative to their design requirements.



FB Series ball valves should only be used in the full on or full off position. Throttling may damage the valve.

Testing

All FB Series valves are factory tested with Nitrogen to 1000 psig (69 bar) at 70°F (20°C).

Warranty

SSP valves are backed by the SSP Limited Life Time Warranty. This warranty is available from your local distributor or at www.mySSP.com.

¹ Add options designators to the end of the Base Part Number in alphabetical order.

² Tube end connection part numbers are formatted "Type" followed by "Size." Example: D6.

Pipe end connections are formatted "Size" followed by "Type." Example: 6PF

If both ends of the valve are the same, then only designate the end connection one time. Example 38PD8-316. If they are different, use both designators together. Example: 38PD88PF-316.

Duolok®, Unilok®, Griplok® and TruFit® are registered trademarks of SSP Corp.
 Expanite® is a registered trademark of Expanite, Inc.
 Swagelok® is a registered trademark of The Swagelok Company
 Parker CPI™ is a trademark of Parker-Hannifin Corp.
 Gyrolok® is a registered trademark of Hoke Inc.

More SSP Products



Tube Fittings

Duolok and Griplok two-ferrule and Unilok® single ferrule tube fittings provide leak-tight installation even when intermixed with Swagelok®, Hoke Gyrolok® and Parker CPI™ fittings.



Valves

The SSP valve offering includes ball, check, metering, needle, toggle, plug, bleed, and purge valves for pressures up to 10,000 psig.



Tubing

SSP offers straight and coiled seamless 316 stainless steel instrumentation tubing for instrumentation, process and utility applications.



Pipe Fittings

TruFit and TruFit 10K pipe fittings are available in a wide range of weld, threaded and flared connections.



Filters

SSP in-line and tee-type filters trap particles to clean sample fluids and protect sensitive process and analytical instrumentation components and equipment.



Tools & Accessories

SSP professional hand tools, power tools and installation training make quality tube system installation faster and easier.



Quick Connects

SSP offers single-end shutoff, double-end shutoff, and full-flow quick connects for instrumentation and process applications.



SSP

Founded 1926

Privately owned, third generation business

Modern single-site vertically integrated manufacturing facility

DFARS-compliant raw material

ISO 9001 quality management system

Limited Lifetime Warranty



8250 Boyle Parkway • Twinsburg, OH 44087

330-425-4250 • www.mySSP.com